

Michelangelo

Hi speed 5-axis machining centres

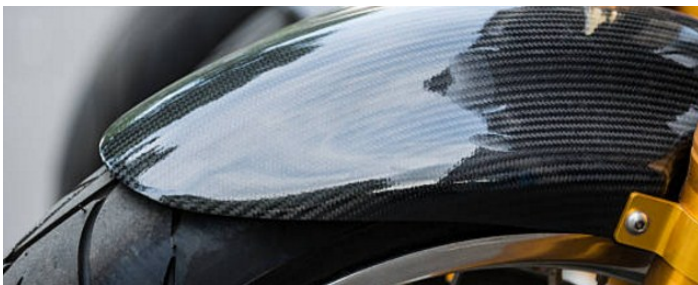



**ALUMINUM
LIGHT ALLOYS**

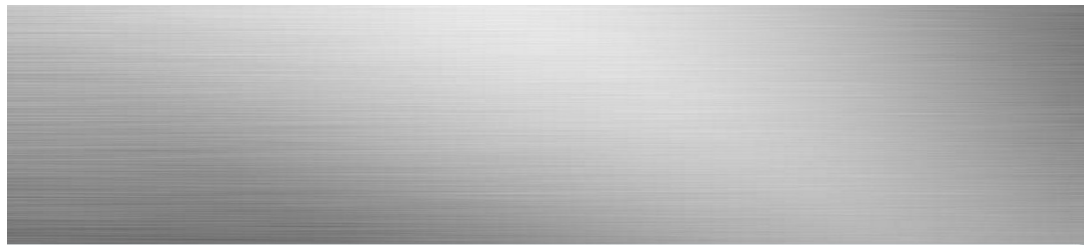

**PLASTICS
RESINS**



COMPOSITES

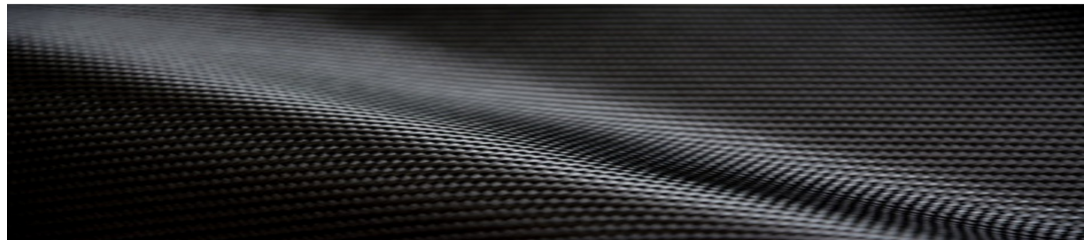

WOOD



Michelangelo: the best quality, flexibility and productivity with the top of 5-axis technology

Michelangelo is a range of last generation 5-axis interpolating machining centres, designed to work the most **advanced material**; composites, special resins, plastics, aluminium, light alloys, wood.

Created to perform at **high speed** on the most **complex 3D shapes**, it is used in many sectors, from molds to thermoformed components to industrial components for the automotive industry, boats, aeronautics, furniture and more.

A compact design with a large machining volume together with high precision and reliability make it the ideal choice to be efficient in the company and offer the highest quality available today.

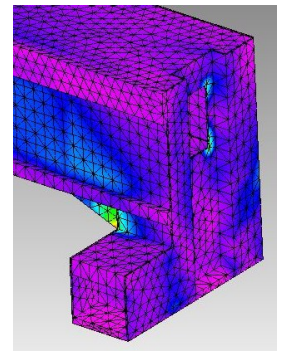
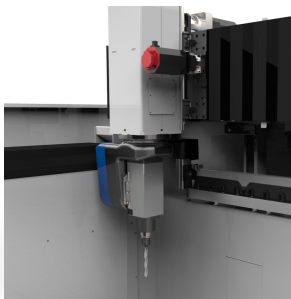
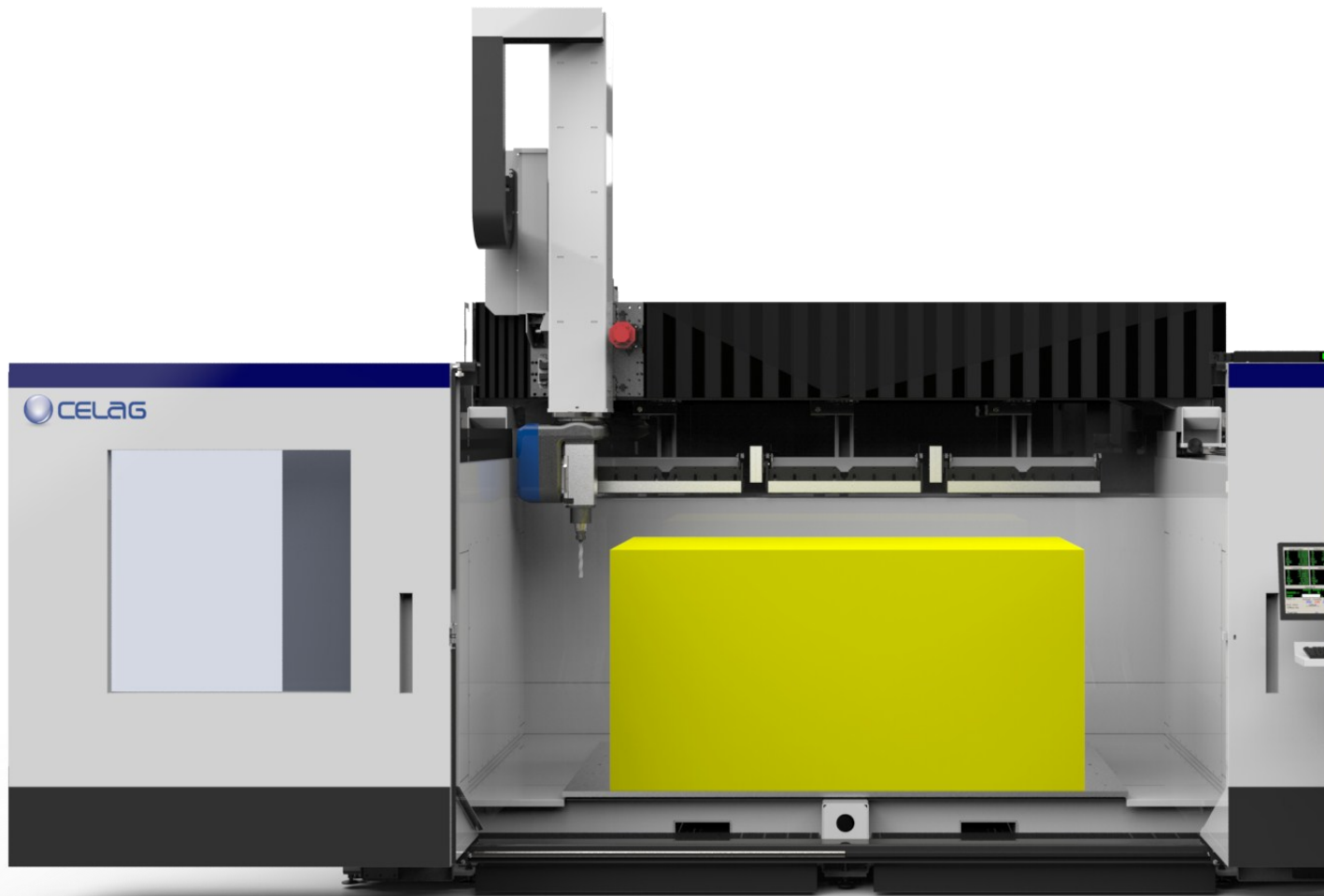

Maximum access to the work area even with manual or automatic movement systems thanks to the large sliding doors without upper beam.

Wide range of operating groups. Efficient and performing.

Engineered structure to give the best precision and working speed.

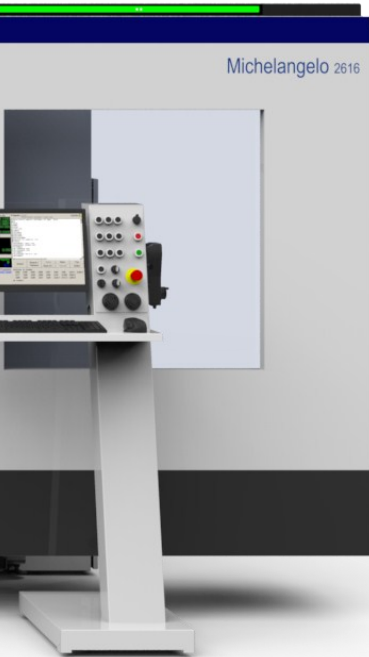

QUALITY

The stiffness of Michelangelo's structure, the powerful brushless motors and latest generation guides guarantee very **high dynamics and precision**. Combining these exceptional performances with powerful electro-spindles, the result is as a leader.

COMFORT AND SECURITY

The **working table** can be **easily loaded** and is **very accessible** even with manual and automatic lifting systems thanks to the sliding doors without upper beam.

Cleaning and service operations are simple while chips can be collected in dedicated containers that are integrated with the machine and easily removable.

All the movement elements and the guides are covered with special devices to protect them from chips and dust extending their life and performance.

Even the standard configurations are equipped with an Ethernet interface to connect to the company network and allow a fast and incisive service.

CUSTOMIZATION

Every customer has specific requirements, so our team of experts analyse with the customer each application proposing the best solution in terms of performance and costs.

This is possible because Celag pay specific attention to **modularity and flexibility** concepts during all the design phases. This allow us to build every detail of the Michelangelo on the precise needs of each customer. For example, tables, clamping systems, software and solutions for different types of material.

The architecture specifically designed to integrate the machine with the most modern automation systems makes the Michelangelo the ideal solution to increase production efficiency.

RESOURCES EFFICIENCY

An important target during the design phase is to obtain an efficient, ecological machine that provide a long service.

In fact, intelligent energy management systems guarantee maximum power during work phases and reduce waste in stops. The stand-by strategy of the Michelangelo as well as representing an energy saving guarantees a longer life of the components.

WORKING TABLE

To meet the needs of each customer and propose the right solution, with Michelangelo there are different versions of the table on which you can use any clamping system and material.

Traditional and pneumatic clamps, standard or special vacuum devices can be easily fixed to the table and connected to the vacuum system.

In addition to the most used tables, CELAG evaluates together with the customer, customized support and fastening solutions to obtain the highest level of performance.

Aluminum table

Suitable for processing wood, plastics, composites, aluminum, light alloys

Configuration with hole grid or with threaded bushings for simple positioning using customer's fastening systems

Other solutions:

- Vacuum suction cups for a reliable and delicate fixing
- Clamps or other pneumatic fixing systems
- T-slots for the clamps

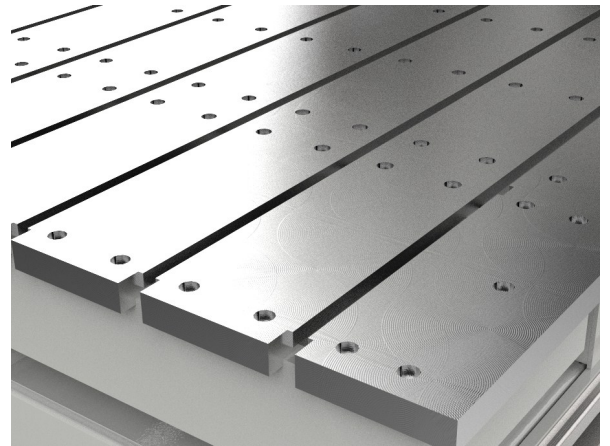

Aluminum matrix table

Suitable for wood and aluminum processing

Configuration with milled channels for insertion of the sealing cord along the perimeter of the piece to be machined or the customer's device to be fixed to the plane.

The most common suction cups can also be used if the piece needs to be raised

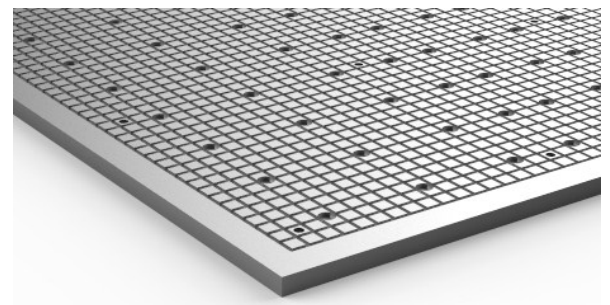

Phenol resin matrix table

Suitable for wood processing

Configuration with milled channels for insertion of the sealing cord along the perimeter of the piece to be machined or the customer's device to be fixed to the plane.

The most common suction cups can also be used if the piece needs to be raised

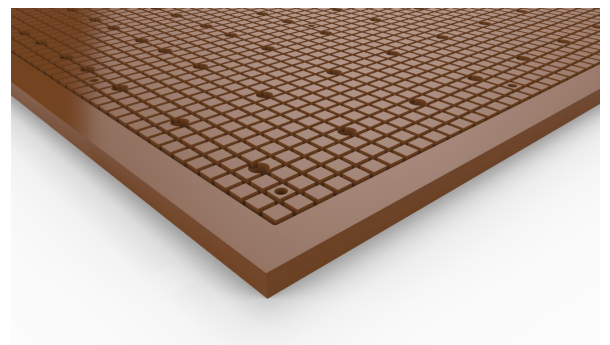



OPERATING UNITS

Michelangelo is a guarantee of quality and for this reason we install only high performance aggregates and electro-spindles that guarantee **high torque even at low speed**

The HSK interface guarantees torque transmission, speed and precision when changing tools.

CELAG has a range of cooling systems that are used to obtain excellent quality and extend tool life, allowing the correct chip discharge in all working conditions.

Chip and dust require special solutions for each material. For example for the aluminum machining it is recommended the use of nebulized refrigerating liquids while for the plastics it is recommended the ionized air system that eliminates the electrostatic charges from the chip preventing it from sticking to the pieces. In addition, dust extraction systems are also available that connect to the customer's centralized vacuum system or dedicated vacuum cleaners.

Electro-spindles range	Use
Power 7/8,7 kW Type HSK F63 Max speed 20.000 rpm Nominal speed 12.000 rpm Liquid cooled	Suitable for plastics machining
Power 11/13 kW Type HSK F63 Max speed 20.000 rpm Nominal speed 12.000 rpm Liquid cooled	Suitable for plastics, composites, wood machining
Power 15/18 kW Type HSK F63 Max speed 24.000 rpm Nominal speed 9.000 rpm Liquid cooled	Suitable for composites, wood machining

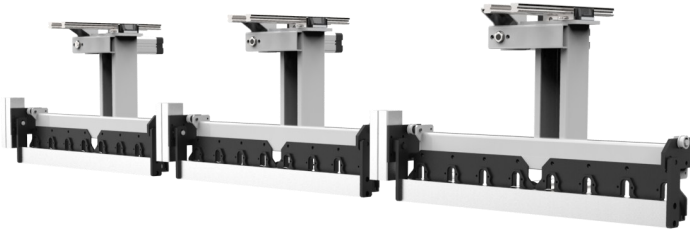

TOOL CHANGER

Saving time during the tool change phase is important to ensure **high productivity** and this depends on the performance level of the tool magazine.

This is why mobile modular tool changer with high performances are planned.

It is possible to install 1 or more tool changer units on the machines

CONSOLLE and SW

Our goal is to make the customer as efficient and competitive as possible.

For this we provide the Michelangelo with the most advanced and modern CNC systems and software. A perfect control of the machining, high dynamics and the possibility to connect the machine to the company network and to the internet, allow an excellent final result.



COLLECTION and CHIP EXPULSION

Speeding up machine cleaning operations means efficiency.

Manual chip extraction and automatic removal systems make the Michelangelo fast to use and always ready.

All-round Service

Always on-line service and assistance

On line with CELAG

We want you to forget all the bad experiences with bad telephone assistance.

We know that when you need our help you need it right away to be at the top of production and as fast as possible. A well-trained and motivated staff is always ready to solve every problem.

We will be happy to inform you about news, additional services, and make offers or orders for you as well.

SERVICE

Having the full availability of your machine and being able to work efficiently is essential for CELAG's customers

This is why we have a team of experienced technicians ready to go and very well organized spare parts management.

TECHNICAL DATA

	Michelangelo 2816	Michelangelo 2616
Electro-spindles	Power 7/8,7 kW Power 11/13 kW <i>See table page 7</i>	Power 15/18 kW <i>See table page 7</i>
Axis	Axis X,Y,Z: pignon-rack A/C: hollow shaft	
Table	<ul style="list-style-type: none"> - Steel T-slot table - Aluminum flat table - Aluminum matrix table - Phenol resin matrix table - Other on request 	
Axis range	X = 2.800mm Y = 1.600mm Z = 1.300mm A = $\pm 120^\circ$ C = $\pm 220^\circ$	X = 2.600mm Y = 1.600mm Z = 1.200mm A = $\pm 120^\circ$ C = $\pm 245^\circ$
Rapid traverse	X-Y-Z = 80 m/min A/C = 75 °/sec	X-Y-Z = 80 m/min A/C = 200 °/sec
Positioning accuracy	0,078 mm	
Repeat accuracy	0,032 mm	
Tool warehouse	8-position travelling linear tool warehouse 16-position travelling linear tool warehouse 24-position travelling linear tool warehouse Other on request	

The information in this brochure is indicative and contains current descriptions and performance. Without any warning they can be modified due to further product development. The technical data can change according to the chosen composition. The descriptions and data on performance are therefore binding only if expressly agreed in writing in the contract. For demonstration needs, some images may include optional accessories.

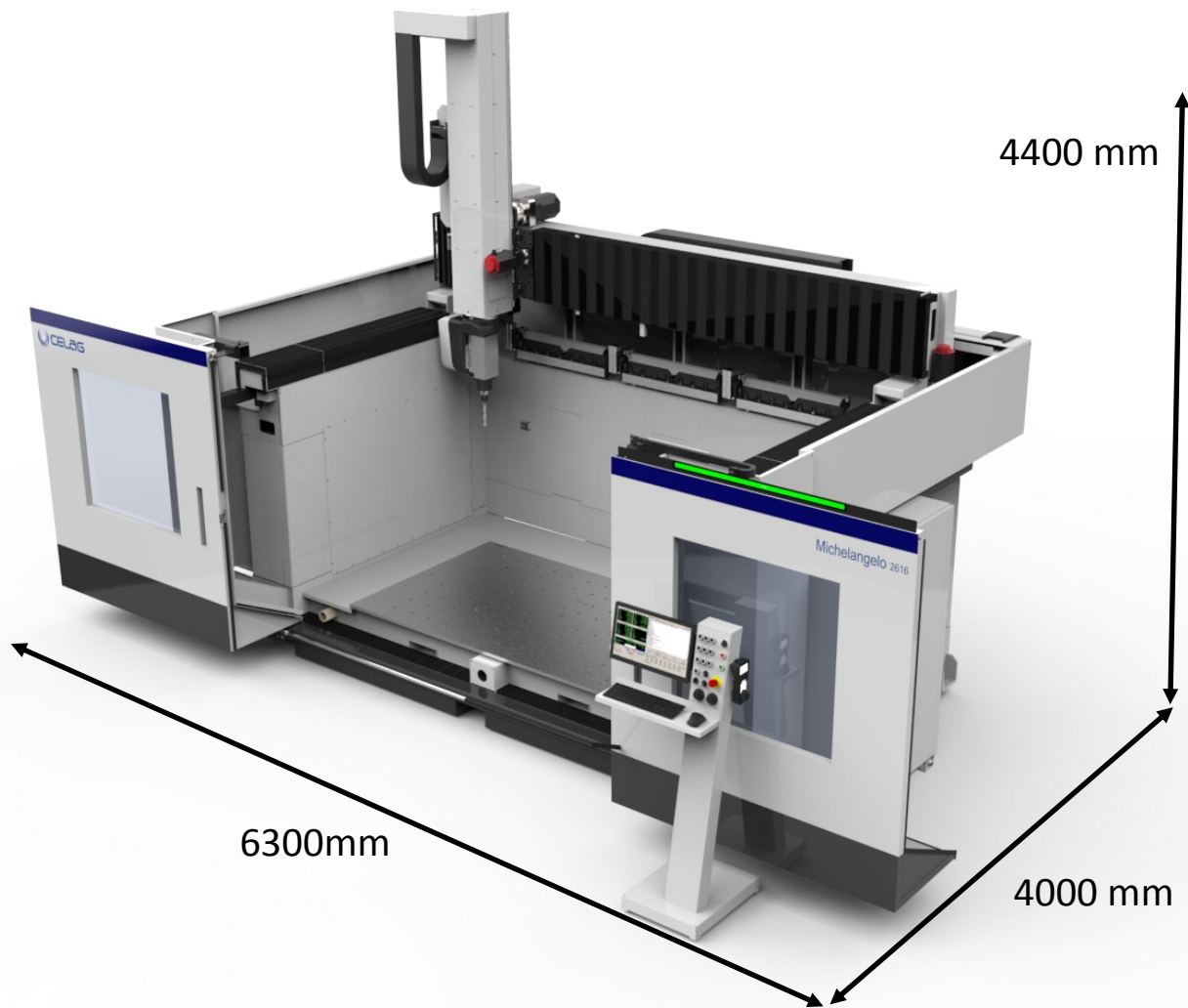

The attention to the needs of each individual customer is what sets us apart.

CELAG has a highly qualified staff, always available to provide support during purchase and after-sales.

The range of Michelangelo machines includes different sizes for those who need more or less work volume.

For those who have special performance requirements, it is possible to study set-ups and customized solutions.

For those who are at the first purchase will be accompanied in all decisive stages with competence and attention.



www.celag.it - info@celag.it